



Halo Refrigeration

Edition : January 2017

Retail Prices (Ex GST)

www.halorefrigeration.com.au





Benefits of Buying from Halo Refrigeration— 1300 673

- | | |
|--|------------------------------|
| ⇒ Australian company, Australian Call Centre | ⇒ Australian product manuals |
| ⇒ Spare parts available | ⇒ Electrically compliant |
| ⇒ MEPS approved | ⇒ Foodsafe |

Halo Catalogue Index

- ◆ Halo Fridges & Freezers
- ◆ Medical Fridges 4U
- ◆ Cyberchill
- ◆ Manitowoc Ice Machines
- ◆ Orford Sign Shop



Contact Halo Refrigeration

Phone : 1300 ORFORD (673 673)

Web : www.halorefrigeration.com.au

Sales@halorefrigeration.com.au





2016 NEW PRODUCTS

Halo SGR 25- 1G 510 Litre Fridge RRP \$4,200 + GST

Dimensions : 640mm w x 800mm d x 2050 h

Capacity : 510 Litres

Operating Temperature : 1°C—8°C

Tested to 35°C ambient

Shelves : 4

Digital Temperature Controller

Weight 150 kg

Halo SGF 25- 1G 510 Lt Freezer RRP \$5,800 + GST

Dimensions : 640mm w x 800mm d x 2050 h

Capacity : 510 Litres

Operating Temperature : -18°C—-27°C

Tested to 35°C ambient

Shelves : 4

Digital Temperature Controller Weight 150 kg

PLAN VIEW

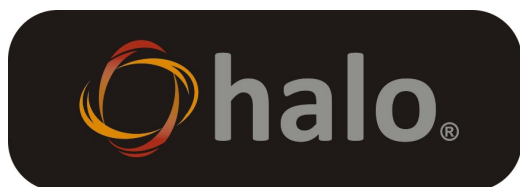
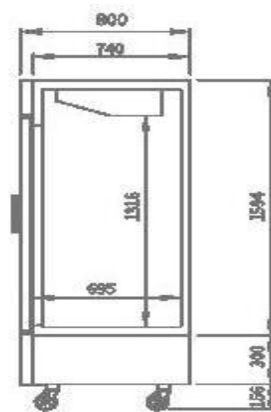
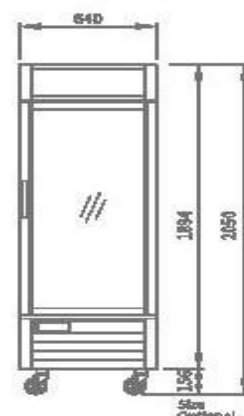
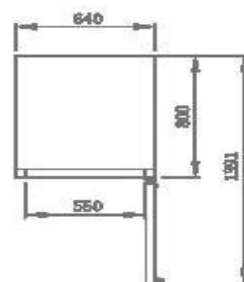

Contact Halo Refrigeration

Phone : 1300 673 673

Web : www.halorefrigeration.com.au

Sales@halorefrigeration.com.au





halo®



HALO FOOD SERVICE RANGE



Halo TGF-5SD

Freezer

RRP \$4173 + GST

167 litre freezer with LED lights

Triple Pane Heated Glass doors with heat reflecting film

Self closing door

-16 to -24 degrees

External : 635 W x 590 D x 775 H

10 Amp plug

R404A Refrigerant

3 shelves standard

weight : 83 kg

Halo TGM-5SD

Refrigerator

RRP \$2700+ GST

167 Litre refrigerator with LED lights

Temp : 0—10 degrees

Levelling Feet

Double Pane glass doors with Heat Reflecting film

R134a Refrigerant

3 shelves standards

External : 635 W x 590 D x 775 H

Weight 69kg

10 Amp plug



Contact Halo Refrigeration

Phone : 1300 673 673

Web : www.halorefrigeration.com.au

Sales@halorefrigeration.com.au





halo®



HALO FOOD SERVICE RANGE

TOG TGM-7SD Refrigerator 215 Litres \$2785 + GST

Capacity : 215 litres

Temperature Range : 0—10 degrees

Levelling Feet

LED lights

Double pane Glass doors with Heat reflecting film

Weight : 77kg

Dims : 635 w x 590 d x 970 h (mm)

Bottom Mount compressor Unit with R134a Refrigerant

Self-closing and stay open door features

4 shelves as standard



New for 2017



Halo HR 350 Slim Refrigerator 386 Litres \$1592 + GST

Temperature Range 1—10 degrees

Double Pane Glass Door with tempered glass

Dims : 620 w x 610 d x 1945 h (mm)

Weight : 86 kg

Operating Temperature : 0—10 degrees Celcius

Door Lock standard

Digital Dixell Blue Line Temperature controller

Refrigerant R600a

Self closing door with double glazed safety glass with single heat reflective Low E glass

4 castors, 2 with brakes

Zanussi compressor

Built in advertising sign with light

Tested to 35 Degrees



Contact Halo Refrigeration

Phone : 1300 673 673

Web : www.halorefrigeration.com.au

Sales@halorefrigeration.com.au





HALO FOOD SERVICE RANGE

Halo TGF-10SD Single Door Freezer 263lt RRP \$4965 + GST

LED lights

Triple Pane Heated Glass doors with heat Reflecting Film

Self closing door. Freezer has levelling feet.

R404A refrigerant

Rated Temp -16 to -24 degrees

4 shelves as standard

655W x 590 D x 1380 H

Weight 89 kg

Available in black or white

10amp Insulated Australian Plug



Halo TGM-10SD

263 Litres

\$3585 + GST

Modern Design

LED Lighting-Brighter and longer lasting LED lights provide attractive

enhanced illumination compared to fluorescent lights, Energy saving

Efficient Refrigeration System

Double Pane Glass Doors with Heat Reflecting Film

High-Density Polyurethane Insulation

Self-closing and stay open door features

Bottom Mount Compressor Units with R134a Refrigerant

4 Shelves as standard

External Dims: W655 x D590 x H1380mm

Internal Dims: W545 x D475 x H1020mm

Weight 89kg. External Finish Colour Black Or White

10Amp Insulated Australian Plug



Contact Halo Refrigeration

Phone : 1300 673 673

Web : www.halorefrigeration.com.au

Sales@halorefrigeration.com.au





halo®



HALO FOOD SERVICE RANGE

HALO TGM-12SD Refrigerator RRP \$3675 + GST

320 Litre capacity Temperature : 0—10 degrees

4 Shelves Weight : 99kg

Refrigerant : R134a

Dimensions : 655 w x 590 D x 1600 H

Movement : Levelling Feet

Shadow Free Advertising Panel

Modern sleek design



Contact Halo Refrigeration

Phone : 1300 673 673

Web : www.halorefrigeration.com.au

Sales@halorefrigeration.com.au





Halo TGF-15SD Freezer RRP \$6090 + GST

450 litre freezer with Digital Temperature Control

LED lights

-16 to -24 degrees

External : 670W x 630D x 1920H

Internal : 560W x 515 D x 1560H

5 shelves standard weight : 142kg 10 Amp plug

Available in Black or White



Halo TGM-15SD Refrigerator RRP \$ 4515 + GST

450 litre refrigerator

LED lights

External : 670W x 630D x 1920H

Internal : 560W x 515D x 1560H

5 shelves standard

weight: 109kg 10 Amp plug

Available in black or white



Contact Halo Refrigeration

Phone : 1300 673 673

Web : www.halorefrigeration.com.au

Sales@halorefrigeration.com.au





halo®



Halo TGM-23SD

Refrigerator

RRP \$4875 + GST

597 litre refrigerator with LED lights with Shadow free advertising panel

Double pane glass doors with heat reflective film Bottom Mount with R134A

External : 685W x 770D x 1955H

Internal : 585W x 655 D x 1535H

5 shelves standard weight : 150kg 10 Amp plug Available in Black or White



Halo SGF-25-1

Freezer

RRP \$5800 + GST

510 litre freezer with LED lights with Shadow free advertising panel

Dims : 640 w x 800 D x 2050 H (inc castors)

Door locks / Door open warning / Digital controller / Digital Temperature Display

4 adjustable shelves / dual vertical interior LED strip light

10 AMP Australian plug

Shipping weight : 150 kg

Halo TGF-23SD

Freezer

RRP \$ 7050 + GST

597litre Freezer with LED lights with Shadow Free Advertising Panel

No electrical Frame Heater is needed due to compressor produced heat up the door

Triple Pane heated Glass doors with heat reflective film

Bottom mount compressor units with R404A

Rated Temp : -16 to -24c

External : 685W x 770D x 1955H

Internal : 585W x 655D x 1535H

5 shelves standard weight: 175kg 10 Amp plug Available in black or white



Contact Halo Refrigeration

Phone : 1300 673 673

Web : www.halorefrigeration.com.au

Sales@halorefrigeration.com.au





Halo TGF-35SD Slimline Freezer RRP \$ 9675 + GST

1048 Lt Freezer

Digital Temperature control system

LED Lights

Shadow free advertising panel

Temperature -16 to -24 degrees

External : 1004W x 809D x 19556H

Internal : 904W x 699D x 1535H

Weight : 231kg

Available in Black or white

15 Amp Insulated Australian Plug



Halo TGM-35SD Slimline Refrigerator RRP \$ 5975 + GST

1047 litre refrigerator

LED lights

External : 1004 W x 809 D x 1956 H

Internal : 904 W x 699 D x 1535 H

10 shelves standard weight 197 kg 10 Amp plug

Available in black or white



Contact Halo Refrigeration

Phone : 1300 673 673

Web : www.halorefrigeration.com.au

Sales@halorefrigeration.com.au





Halo TGF-47SD Freezer RRP \$ 10950 + GST

1308 litre freezer with Digital Temperature Control

LED lights

-16 to -24 degrees

External : 1299 W x 809D x 1956 H

Internal : 1199 W x 699 D x 1535H

10 shelves standard weight : 265 kg 15 Amp plug

Available in Black or White



Halo TGM-47SD Refrigerator RRP \$6950 + GST

1308 litre refrigerator

LED lights

External : 1299 W x 809 D x 1956 H

Internal : 1199 W x 699 D x 1535 H

10 shelves standard weight: 230kg

10 Amp plug

Available in black or white



Contact Halo Refrigeration

Phone : 1300 673 673

Web : www.halorefrigeration.com.au

Sales@halorefrigeration.com.au





Halo TGF-72SD

Freezer 2019LT FREEZER

RRP \$15,665 + GST

Digital Temperature control

LED lights

-16 to -24 degrees

External : 1981 W x 809D x 1956 H

15 shelves standard

weight : 356 kg

15 Amp plug

Available in Black or White



Halo TGM-72SD

2019 litre REFRIGERATOR

RRP \$10,095 + GST

External : 1981 W x 809 D x 1956 H

Internal : 1891 W x 709 D x 1556 H

15 shelves standard

weight: 310kg

15 Amp plug

LED lights

Available in black or white



Contact Halo Refrigeration

Phone : 1300 673 673

Web : www.halorefrigeration.com.au

Sales@halorefrigeration.com.au





Halo TOG G1F-650

Freezer

RRP \$4860 + GST

650 litre freezer with Digital Temperature Control

LED lights

-16 to -24 degrees

External : 685 W x 760D x 1984

4 shelves standard weight : 171 kg 10 Amp plug



Halo TOG G2F-1250

Freezer

RRP \$7950 + GST

1250 litre refrigerator

LED lights

-16 to -24 degrees

External : 1382 W x 760 D x 1984 H

10 shelves standard weight: 266kg 15 Amp plug



Contact Halo Refrigeration

Phone : 1300 673 673

Web : www.halorefrigeration.com.au

Sales@halorefrigeration.com.au





Halo TOG KRF 25-2 Dual Temp Fridge / Freezer RRP \$5,090 + GST

Stainless Steel top Mount Dual Temperature

Fridge with Freezer Two compressor system

Capacity in litres - Freezer 242 litres / Fridge 222 litres = 664 litres

Temperature—Fridge 1c to 8c Freezer— -21c to -12c

4 shelves (2 per door)

Fridge—R-134A 4.4amps power—w673, 15amp insulated Australian plug

Dimensions : 640 W x 850 D x 1935 H (including castors)

Weight : 150kg



Contact Halo Refrigeration

Phone : 1300 673 673

Web : www.halorefrigeration.com.au

Sales@halorefrigeration.com.au





Halo TOG KRF 45-2 Dual Temp Fridge / Freezer RRP \$7135 + GST

Stainless Steel top Mount Dual Temperature

Fridge with Freezer Two compressor system

Capacity in litres - Freezer 464 litres / Fridge 645 litres = 1109 litres

Blue—Freezer, Green—Fridge

Temperature—Fridge 2c to 6c Freezer— -21c to -12c

6 shelves (3 per door)

Fridge—R-134A 4.4amps power—w673, 15amp insulated Australian plug

Dimensions : 1260W x 800D x 1935H (including castors)

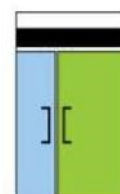

Halo TOG KRF 45-4 Dual Temp Fridge / Freezer RRP \$7650 + GST

Stainless Steel top Mount Dual Temperature

Fridge with Freezer Two compressor system

Capacity in litres - Freezer 464 litres / Fridge 642 litres = 1106 litres

Blue—Freezer, Green—Fridge

Temperature—Fridge 2c to 6c Freezer— -21c to -12c

6 shelves (3 per door)

Fridge—R-134A 4.4amps power—w673, 15amp insulated Australian plug

Dimensions : 1260W x 800D x 1935H (including castors)

Weight : 150kg



Contact Halo Refrigeration

Phone : 1300 673 673

Web : www.halorefrigeration.com.au

Sales@halorefrigeration.com.au





Halo TOG KDU65-3 Dual Temp Fridge / Freezer RRP \$8815 + GST

Stainless Steel top Mount Dual Temperature Two compressor system

Capacity in litres - Freezer 555 litres / Fridge 1275 litres = 1830 litres

Blue—Freezer, Green—Fridge

Temperature—Fridge 2c to 6c Freezer— -21c to -12c

9 shelves (3 per door)

Fridge—R-134A 4.4amps power—w673, 15amp insulated Australian plug

Dimensions : 1900W x 800D x 1935H (including castors)

Weight : 175kg

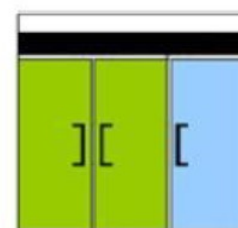

Halo TOG KDU65-6 Dual Temp Fridge / Freezer RRP \$10,130 + GST

Stainless Steel top Mount Dual Temperature 6 half door capacity

Fridge with Freezer Two compressor system

Capacity in litres - Freezer 555 litres / Fridge 1175 litres = 1730 litres

Blue—Freezer, Green—Fridge

Temperature—Fridge 2c to 6c Freezer— -21c to -12c

9 shelves (3 per door)

Fridge—R-134A 4.4amps power—w673, 15amp insulated Australian plug

Dimensions : 1900W x 800D x 1935H (including castors)

Weight : 177kg

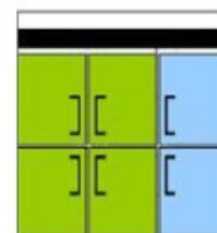

Contact Halo Refrigeration

Phone : 1300 673 673

Web : www.halorefrigeration.com.au

Sales@halorefrigeration.com.au





halo®



HALO FOOD SERVICE RANGE— The Halo K Series



KR25-1 Fridge

KF25-1 Freezer



KR45-1 Fridge

KF45-1 Freezer



KR65-1 Fridge

KF65-1 Freezer



Contact Halo Refrigeration

Phone : 1300 673 673

Web : www.halorefrigeration.com.au

Sales@halorefrigeration.com.au





halo®



HALO FOOD SERVICE RANGE— The Halo K Series



The K Series Features

- Designed to 40 Degrees ambient operating temperature
- Requires one standard power point : - 240V 50Hz 10 amp
- Digital Temperature Display
- 3 height adjustable shelves per door. Individual shelves behind each door maximize storage configurations
- Stainless steel construction for superior corrosion resistance
- Stainless steel internal floor with coved corners allows for easy cleaning and sanitizing
- Large castors for ease of cabinet movement
- Solid lockable doors. Designed with recessed handle and self closing hinging with 90 degree dwell feature
- LED interior lighting
- One piece door gaskets, removable without tools for easy cleaning
- Automatic energy efficient hot gas condensate disposal. No drainage required
- Internal Pressure release valve

Contact Halo Refrigeration

Phone : 1300 673 673

Web : www.halorefrigeration.com.au

Sales@halorefrigeration.com.au





halo®



HALO FOOD SERVICE RANGE— The Halo K Series



Model	Temp	Doors	Net Volume	Shelves	Dimensions	Power 220v	Shipping Weight
Halo KR25-1	Refrigerator 1~ 8 degrees	1	574	3	640w x 850d x 1926h	314w	115
Halo KF25-1	Freezer -21 ~ -12 degrees	1	574	3	640w x 850d x 1926h	496w	120
Halo KR45-2	Refrigerator 1 ~ 8 degrees	2	1215	6	1260w x 850d x 1926h	366w	190
Halo KF45-2	Freezer -21~-12 degrees	2	1215	6	1260w x 850d x 1926h	774w	200
Halo KR65-3	Refrigerator 1—8 degrees	3	1876	9	1900w x 850d x 1926h	732w	280
Halo KF65-3	Freezer -21 ~ 12 degrees	3	1876	9	1900w x 850d x 1926h	1346w	280

Note : the depth includes 50mm for the rear condensate tray

Contact Halo Refrigeration

Phone : 1300 673 673

Web : www.halorefrigeration.com.au

Sales@halorefrigeration.com.au





HALO FOOD SERVICE RANGE— The Halo K Series



SPECIFICATIONS

- Electronic Controller—Provides precise and constant temperature.
- High-tech Monitor—The monitor digitally displays the present temperature. You can easily change the temperature by adjusting the thermostat
- Lighting : LED interior lights activated by rocker switches mounted above each door.
- Hot Gas Condensate System : The condensate system surfaces have been specially treated to resist corrosion. This not only increases efficiency without the risk of refrigerant leakage from corrosion, but also prevents the overflow of condensate water.
- Door Pressure Release Device : Pressure relief doors are designed to eliminate vacuum pressure and allow easy, instant door opening
- Insulation : 50mm high pressure injected polyurethane foam
- Gasket : PVC welded one piece magnetic gasket. Removable without tools for easy cleaning
- Hinging : Self closing with 90 degrees dwell open
- Shelves : 3 adjustable, PVC coated, steel shelves per door
- Castors : 100mm heavy duty castors, front locking
- Electrical : Cabinets are ready for connection to a 220volt 50hz 10amp GPO. It is recommended that a dedicated GPO is used.

Contact Halo Refrigeration

Phone : 1300 673 673

Web : www.halorefrigeration.com.au

Sales@halorefrigeration.com.au





HALO FOOD SERVICE RANGE— The Halo K Series



ELEVATIONS. (not to scale)

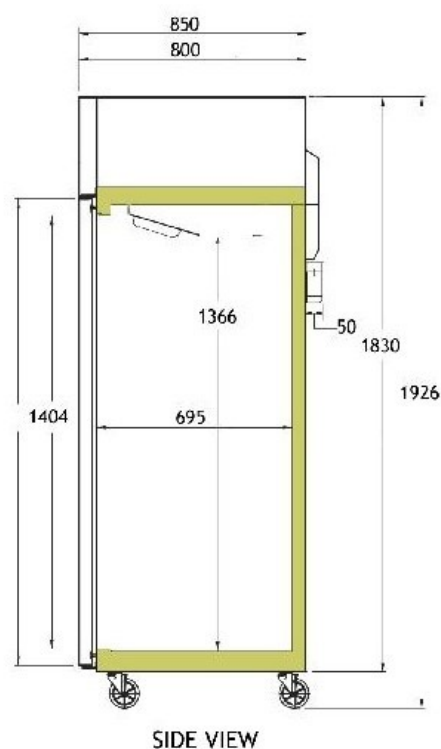
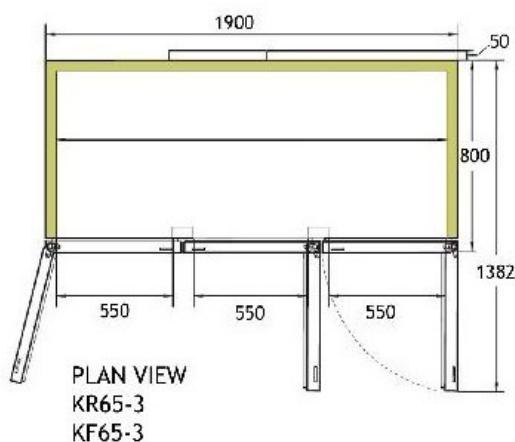
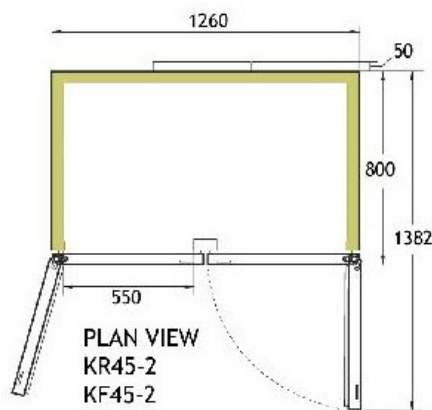
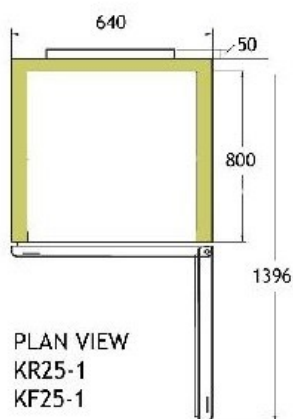

Contact Halo Refrigeration

Phone : 1300 673 673

Web : www.halorefrigeration.com.au

Sales@halorefrigeration.com.au





HALO FOOD SERVICE RANGE— The Halo K Series

Halo KR25-1 574 litre Refrigerator RRP \$3595 + GST

Stainless Steel Top Mount Single door refrigerator, 574 litre
Ventilated Cooling Temp Range : 1c to 8c
Digital Controller and Display 3 Adjustable shelves
Refrigerant R-134a Amps 3.5 Power - W366
10 Amp
Dimensions: 640 W x 850 D x 1926 H (Including Castors)
Weight—80kg



Halo KR45 -2R Refrigerator 1215 litre RRP \$4905 + GST

Stainless Steel Top Mount 2 door refrigerator, Volume 1215 litres
Temp Range : 1 degree to 8 degrees
3 Adjustable shelves per Door
Digital controller and Display
Refrigerant R-134a 10 Amp Australian Plug
Dimensions W 1260 x D 850 x H 1926 mm Including castors
Weight— 142 kg

Halo KR65-3R 3 Door Refrigerator 1876 litre RRP \$7470 + GST

3 Door Top Mount Refrigerator Volume : 1876 litres
Stainless Exterior & Interior
3 Adjustable Shelves per Door Refrigerant R-134a
Fan Cooling Type Digital Control and Display
Temp Range 1 degree to 8 degrees
Weight 167KG
W 1900 x D 800 x H 1926 mm Including the castors
D830mm inc Evaporator Tray H2106 Inc castors
15 Amp Australian Plug



Contact Halo Refrigeration

Phone : 1300 673 673

Web : www.halorefrigeration.com.au

Sales@halorefrigeration.com.au





HALO FOOD SERVICE RANGE— The Halo K Series

Halo KF25-1F Freezer 574 litre RRP \$4050 + GST

Stainless Steel Top Mount Single door freezer, 574 litre
 Ventilated Cooling Temp Range -12c to -25c
 Digital Controller and Display 3 Adjustable shelves
 Refrigerant R-404a Amps 3.5 Power - W496 10 Amp
 Dimensions: 640 W x 850 D x 1926 H (Including Castors)
 Weight—80kg

Energy consumed 16.45 kWh / 24 hrs

Rated at 40 degree ambient



Halo KF45 -2F Freezer 1215 litre RRP \$6295 + GST

Stainless Steel Top Mount 2 door freezer, Volume 1215 litres
 Temp Range -12c to -21c
 3 Adjustable shelves per Door
 Digital controller and Display
 Refrigerant R-404a Amps 5.3, Power W774 10 Amp Australian Plug
 Dimensions W 1260 x D 850 x H 1926 mm Including castors
 Weight— 142 kg



Halo KF65-3F 3 Door Freezer 1876 litre RRP \$9090 + GST

3 Door Top Mount Freezer Volume : 1876 litres
 Stainless Exterior & Interior
 3 Adjustable Shelves per Door
 Refrigerant R-404a
 Fan Cooling Type Digital Control and Display
 Temp Range -12 degrees to -21c
 Power 1346 w Amps 8.5
 Weight 167KG 10AMP plug
 W 1900 x D 800 x H 1926 mm Including the castors



Contact Halo Refrigeration

Phone : 1300 673 673

Web : www.halorefrigeration.com.au

Sales@halorefrigeration.com.au





HALO FOOD SERVICE RANGE— The Halo K Series

Halo KR25-1G Refrigerator 574 litre RRP \$4215 + GST

Stainless Steel 1 door top mount refrigerator with lockable glass display door
Temperature range 0c—8c
Refrigerant R-134a
Dimensions : 640 w x 850 d x 1926 h mm (including castors)
Weight : 87 kg
240v / 50hz / 1
Energy consumption 5.51 kWh / 24 hr



Halo KR45 -2G Refrigerator 1215 litre RRP \$6075 + GST

Stainless Steel 2 door top mount refrigerator with 1215 litre capacity
Glass doors with key lock
Door open warning
Temperature range : 0 c to 8 c
3 shelves per door plus base
Dimensions : 1260w x 850d 1926h mm (incl castors)
Weight 152kg
Energy consumption 9.65 kWh / 24 hr

Soft touch controller
Digital temperature display
Refrigerant : R134a

Halo KR65-3G 3 Door Fridge 1876 litre RRP \$8795 + GST

Stainless steel interior and exterior
Glass doors with key lock
Door open warning
3 shelves per door plus base
Temperature range : 0c to 8c
Dimensions : 1900w x 850d x 1926h (incl castors)
Weight : 177kg

soft touch controller
Digital temperature display,
internal lighting

Energy consumption 9.65 kWh / 24 hr



Contact Halo Refrigeration

Phone : 1300 673 673

Web : www.halorefrigeration.com.au

Sales@halorefrigeration.com.au





halo®



HALO FOOD SERVICE RANGE— The Halo K Series



Halo KR25-2G 2 Half Door Fridge 572 litre RRP \$4630 + GST

Stainless steel interior and exterior

Glass doors with key lock

Door open warning

3 shelves per door plus base

Temperature range : 0c to 8c

Dimensions : 640 w x 800d x 1926h (incl lockable castors)

Weight : 177g

Running Current 6 Amps, input Power 732w

soft touch controller

Digital temperature display,

internal lighting

Halo KR45-4G 4 Half Door Fridge 1210 litre RRP \$6655 + GST

Stainless steel interior and exterior

Glass doors with key lock

Door open warning

3 shelves per door plus base

Temperature range : 0c to 8c

Dimensions : 1260w x 850d x 1926h (incl castors)

Weight : 152kg

Energy consumption 9.65 kWh / 24 hr

soft touch controller

Digital temperature display,

Internal lighting



Halo KR65-6G 6 Half Door Fridge 1868 litre RRP \$10200 + GST

Stainless steel interior and exterior

Glass doors with key lock

Door open warning

3 shelves per door plus base

Temperature range : 0c to 8c

Dimensions : 1900 w x 850d x 1926h (incl lockable castors)

Weight : 177g

Running Current 6 Amps, input Power 732w

Energy consumption 12.89 kWh / 24 hrs

soft touch controller

Digital temperature display,

Internal lighting

Contact Halo Refrigeration

Phone : 1300 673 673

Web : www.halorefrigeration.com.au

Sales@halorefrigeration.com.au





HALO FOOD SERVICE RANGE— The Halo K Series

Halo KF25-1G Freezer 574 litre RRP \$5095 + GST

Temperature range -21c to -8c 3 shelves
Refrigerant R-404a Digital controller
4.5 Amps, Power 660w
Dimensions : 640 w x 850 d x 1926 h (including lockable castors)
Weight : 95 kg 10 Amp Australian plug
Energy consumption : 16.45 kWh / 24 hrs



Halo KF25 -2G Freezer 572 litre RRP \$5495 + GST

Stainless Steel 2 door top mount freezer with two glass half doors
Door open warning Digital temperature display
Temperature range : -21c to -12 c Refrigerant : R404a
3 adjustable shelves per door plus base
Dimensions : 640 w x 850 d 1926 h mm (incl castors)
Weight : 95 kg

Energy consumption : 16 kWh / 24 hrs

Contact Halo Refrigeration

Phone : 1300 673 673

Web : www.halorefrigeration.com.au

Sales@halorefrigeration.com.au





HALO FOOD SERVICE RANGE— The Halo K Series



Halo KF45 -2G Freezer 1215 litre

RRP \$8665 + GST

Stainless Steel 2 door top mount freezer with glass doors

1215 litre capacity

Door open warning

Temperature range : -21c to -12 c

3 adjustable shelves per door plus base

Digital temperature display

Refrigerant : R404a

Dimensions : 1260 w x 850 d 1926 h mm (incl castors)

Weight 170 kg

Energy consumption : 28.1 kWh / 24 hrs

Halo KF45-4G 4 Half Door Freezer 1210 litre RRP \$9225 + GST

Four half glass door display freezer with 1210 litre capacity

Stainless steel interior and exterior

Glass doors with key lock

Door open warning

3 shelves per door plus base

internal lighting

Temperature range : -21c to -12c

soft touch controller

Digital temperature display,

10 amp plug

Dimensions : 1260 w x 850 d x 1926 h (incl castors)

Weight : 170kg

Energy consumption : 28.1 kWh / 24 hrs



Contact Halo Refrigeration

Phone : 1300 673 673

Web : www.halorefrigeration.com.au

Sales@halorefrigeration.com.au





HALO FOOD SERVICE RANGE



Halo KR65—6 6 Half Door 1868 Lt Refrigerator RRP \$7750 + GST

6 door S/S Top Mount

Temp Range : 0c to +8c

Refrigerant R-134A Amps 6 Power-w 732

Dims : 1900 w x 850 d x 1926 h (mm including castors)

Weight—176kg

Halo AM-50R-PT Pass Through Refrigerator

RRP \$9500 + GST

Pass Through Food Service Refrigerator

Dims : 1314 w x 930 d x 2132 h

Capacity : 1470 litres

Doors : 4 doors (2 front and 2 rear)

Refrigerant : R134a

Digital control system with Self—diagnostic Technology

Amps : 5

Weight : 250kg



Contact Halo Refrigeration

Phone : 1300 ORFORD (673 673)

Web : www.halorefrigeration.com.au

Sales@orford.com.au





halo®



HALO FOOD SERVICE UNDERBENCH

Halo KUF9-1

FREEZER

RRP \$ 3375 + GST

Undercounter freezer—198 litres

All stainless steel 304

Left hand side Embraco Compressor,

EBM Fan Temperature Range : -21c to -12 degrees

1 shelf, weight 72 kg

Refrigerant R404a

LED Digital Display and Soft Touch Controller

Dimensions : 900 w x 700 d x 850 h (mm)

On castors.

10 Amp plug



Halo KUR9-1

REFRIGERATOR

RRP \$ 3115 + GST

Undercounter Refrigerator —198 litres

All stainless steel 304

Left hand side Embraco Compressor,

EBM Fan Temperature Range : 1c to 6c degrees

1 shelf, weight 72 kg

Refrigerant 134A

LED Digital Display and Soft

Touch Controller

Dimensions : 900 w x 700 d x 850 h (mm)

On castors.

10

Amp plug

Contact Halo Refrigeration

Phone : 1300 ORFORD (673 673)

Web : www.halorefrigeration.com.au

Sales@orford.com.au





halo®



HALO FOOD SERVICE K Series UNDERBENCH RANGE



Halo KUR12-2 Undercounter Fridge RRP \$3415 + GST

Embraco compressor, EBM fan Capacity 311 Litre

Temperature Range 0c to 8c, 70mm insulation

Refrigerant Gas : R134a

2 shelves, 3 Amps, input power 314w, Weight 84kg

LED Digital Display and soft touch controller

Dims : 1200 w x 700 d x 850 h (mm) On castors

Halo KUF12-2 Undercounter Freezer RRP \$3710 + GST

Embraco compressor, EBM fan Capacity 311 Litre

Temperature Range : -21c to -12 degrees, 70mm insulation

Refrigerant Gas : R404a

2 shelves, 3 Amps, input power 366w, Weight 84kg

LED Digital Display and soft touch controller

Dims : 1200 w x 700 d x 850 h (mm) On castors



Drawer options available

Contact Halo Refrigeration

Phone : 1300 ORFORD (673 673)

Web : www.halorefrigeration.com.au

Sales@orford.com.au





halo®



HALO FOOD SERVICE K Series UNDERBENCH RANGE

Halo KUR15-2 Undercounter Fridge RRP \$3900 + GST



Embraco compressor, EBM fan Capacity 425 Litre

Temperature Range 0c to 8c, 70mm insulation

Refrigerant Gas : R134a

2 shelves, 3 Amps, input power 314w, Weight 93kg

LED Digital Display and soft touch controller

Dims : 1500 w x 700 d x 850 h (mm) On castors

Halo KUF15-2 Undercounter Freezer RRP \$4100 + GST

Embraco compressor, EBM fan Capacity 425 Litre

Temperature Range : -21c to -12 degrees, 70mm insulation

Refrigerant Gas : R404a

2 shelves, 3 Amps, input power 366w, Weight 84kg

LED Digital Display and soft touch controller

Dims : 1500 w x 700 d x 850 h (mm) On castors



Contact Halo Refrigeration

Phone : 1300 ORFORD (673 673)

Web : www.halorefrigeration.com.au

Sales@orford.com.au





halo®



HALO FOOD SERVICE K Series UNDERBENCH RANGE

Halo KUR18-3 Undercounter Fridge RRP \$4200 + GST



Embraco compressor, EBM fan Capacity 538 Litre

Temperature Range 0c to 8c, 70mm insulation

Refrigerant Gas : R134a

3 shelves, 4.4 Amps, input power 366w, Weight 109kg

LED Digital Display and soft touch controller

Dims : 1800 w x 700 d x 850 h (mm)

On castors

Halo KUF18-3 Undercounter Freezer RRP \$4800 + GST

Embraco compressor, EBM fan Capacity 538 Litre

Temperature Range : -21c to -12 degrees, 70mm insulation

Refrigerant Gas : R404a

3 shelves, 4.4 Amps, input power 613w, Weight 109kg

LED Digital Display and soft touch controller

Dims : 1800 w x 700 d x 850 h (mm)

On castors



Contact Halo Refrigeration

Phone : 1300 ORFORD (673 673)

Web : www.halorefrigeration.com.au

Sales@orford.com.au





HALO FOOD SERVICE K Series **DUAL TEMP UNDERBENCH RANGE**

Halo KURF12-2 Fridge / Freezer Combo RRP \$4500 + GST



Dual temperature 2 Door Undercounter

Freezer Capacity 134 Litre Temp Range -21c to -12c, Gas : 404a

Fridge capacity 136 Litre Temp Range 1c to 5c Gas : 134a

2 doors, 1 shelf per door, 3 Amps, input power 316 w, Weight 87kg

Dims : 1200 w x 700 d x 850 h (mm) On castors

Halo KURF15-2 Fridge / Freezer Combo RRP \$4700 + GST

Dual temperature 2 Door Undercounter

Freezer Capacity 177 Litre Temp Range -21c to -12c, Gas : 404a

Fridge capacity 189 Litre Temp Range 1c to 5c Gas : 134a

2 doors, 1 shelf per door, 3 Amps, input power 316 w, Weight 96kg

Dims : 1500 w x 700 d x 850 h (mm) On castors



Halo KURF18-3 Fridge / Freezer Combo RRP \$4900 + GST

Dual temperature 3 Door Undercounter

Freezer Capacity 151 Litre Temp Range -21c to -12c, Gas : 404a

Fridge capacity 314 Litre Temp Range 1c to 5c Gas : 134a

3 doors, 1 shelf per door, 4.4 Amps, input power 366 w, Weight 112kg

Dims : 1800 w x 700 d x 850 h (mm) On castors

Contact Halo Refrigeration

Phone : 1300 ORFORD (673 673)

Web : www.halorefrigeration.com.au

Sales@orford.com.au





halo®



HALO FOOD SERVICE K Series UNDERBENCH RANGE

Halo KGR9-1 Glass Door Refrigerator RRP \$3245 + GST



1 Door Undercounter Refrigerator Digital display and control
Capacity 137Litre Temp Range 1c to 5c Gas : 134a
1 door with LOW E glass, 1 shelf, Weight 80kg
Dims : 900 w x 700 d x 850 h (mm) On castors

Halo KGR12-2 Glass Door Refrigerator RRP \$3850 + GST

2 Door Undercounter Refrigerator Digital display and control
Capacity 311 Litre Temp Range 1c to 5c Gas : 134a
2 doors with LOW E glass, 2 shelf, Weight 96kg
Dims : 1200 w x 700 d x 850 h (mm) On castors



Halo KGR15-2 Glass Door Refrigerator RRP \$4320 + GST



2 Door Undercounter Refrigerator Digital display and control
Capacity 425 Litre Temp Range 1c to 5c Gas : 134a
2 doors with LOW E glass, 2 shelf, Weight 96kg
Dims : 1500 w x 700 d x 850 h (mm) On castors

Halo KGR18—3 Glass Door Refrigerator RRP \$4975 + GST

3 Door Undercounter Refrigerator Digital display and control
Capacity 538 Litre Temp Range 1c to 5c Gas : 134a
3 doors with LOW E glass, 3 shelf, Weight 127kg
Dims : 1800 w x 700 d x 850 h (mm) On castors



Contact Halo Refrigeration

Phone : 1300 ORFORD (673 673)

Web : www.halorefrigeration.com.au

Sales@orford.com.au





halo®



HALO BACK BAR FRIDGES—900 high



Halo TB6-1G Glass Door Back Bar Fridge RRP \$3230 + GST

1 Door Back Bar Refrigerator with LOW E glass

Capacity 125 Litres

Refrigerant : R134a

Weight 60 kg

Temperature range 1c to 8 c

Dims : 600 w x 515 d x 900 h

Halo TB9-2G Glass Door Back Bar Fridge RRP \$4080 + GST

2 Door Back Bar Refrigerator with LOW E glass

Capacity 190 Litres

Refrigerant : R134a

Weight 60 kg

Temperature range 1c to 8 c

Dims : 900 w x 515 d x 900 h



Halo TB13-3G Glass Door Back Bar Fridge RRP \$4980 + GST

3 Door Back Bar Refrigerator with LOW E glass

Capacity 300 Litres

Refrigerant : R134

Weight 60 kg

Temperature range 1c to 8 c

Dims : 1352 w x 515 d x 900 h



Contact Halo Refrigeration

Phone : 1300 ORFORD (673 673)

Web : www.halorefrigeration.com.au

Sales@orford.com.au





halo®



HALO BACK BAR FRIDGES—800mm high



Halo TB6-1G Glass Door Back Bar Fridge RRP \$3050 + GST

1 Door Back Bar Refrigerator with LOW E glass

Capacity 110 Litres

Refrigerant : R134a

Weight 55 kg

Temperature range 1c to 8 c

Dims : 600 w x 515 d x 800 h

Height includes 10mm stub feet levellers

Halo TB9-2G(800) Glass Door Back Bar Fridge RRP \$3850 + GST

2 Door Back Bar Refrigerator with LOW E glass

Capacity 165 Litres

Refrigerant : R134a

Height includes 10mm stub feet levellers

Weight 70 kg

Temperature range 1c to 8 c

Dims : 900 w x 515 d x 800 h



Halo TB13-3G(800) Glass Door Back Bar RRP \$4740 + GST

3 Door Back Bar Refrigerator with LOW E glass

Capacity 261 Litres

Refrigerant : R134

Weight 95 kg

Height includes 10mm stub feet levellers

Temperature range 1c to 8 c

Dims : 1352 w x 515 d x 800 h



Contact Halo Refrigeration

Phone : 1300 ORFORD (673 673)

Web : www.halorefrigeration.com.au

Sales@orford.com.au





halo®



HALO FOOD SERVICE SALAD AND SANDWICH TABLES



Halo KSR Salad Prep Table 213 Ltrs RRP \$3650 + GST

1 Door Salad Prep Table Buffet Capacity 213 Ltrs

Dims : 900 w x 700 d x 800 h (875mm high with castors) Weight 70kg

1 Door 1 shelf	Refrigerant R134a	Fan Cooling Type
Digital Control	Amps 2.3	Voltage 220 / 50 Power 314 w
Door locks	Interior LED lighting	4" swivel castors with front lock

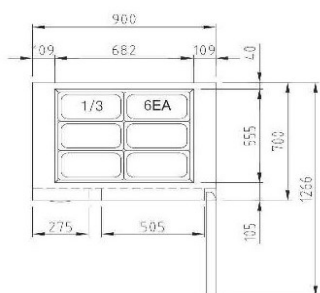

PLAN VIEW

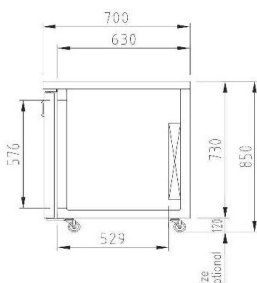

SIDE VIEW

Halo KSR Salad Prep Table 309 Ltrs RRP \$4105 + GST

2 Door Salad Prep Table Buffet Capacity 309 Ltrs

Dims : 1200 w x 700 d x 800 h (875mm high with castors) Weight 82kg

2 Door 2 shelves	Refrigerant R134a	Fan Cooling Type
Digital Control	Amps 2.5	Voltage 220 / 50 Power 314 w
Door locks	Interior LED lighting	4" swivel castors with front lock

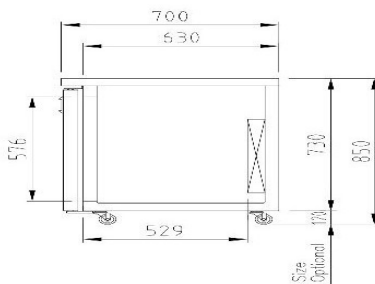

SIDE VIEW

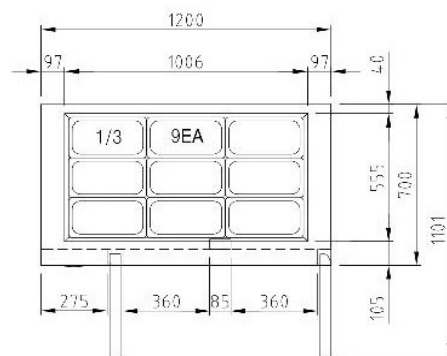

PLAN VIEW

Contact Halo Refrigeration

Phone : 1300 ORFORD (673 673)

Web : www.halorefrigeration.com.au

Sales@orford.com.au





halo®



HALO FOOD SERVICE SALAD AND SANDWICH TABLES



Halo KSR15-2 Salad Prep Table 450 Ltrs RRP \$4519 + GST

2 Door Salad Prep Table Buffet Capacity 450 Ltrs

Dims : 1500 w x 700 d x 800 h (875mm high with castors) Weight 91kg

2 Door 2 shelves Refrigerant R134a Fan Cooling Type

Digital Control Amps 2.5 Voltage 220 / 50 Power 314 w

Door locks Interior LED lighting 4" swivel castors with front lock

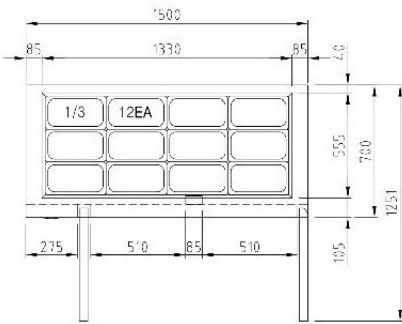

PLAN VIEW

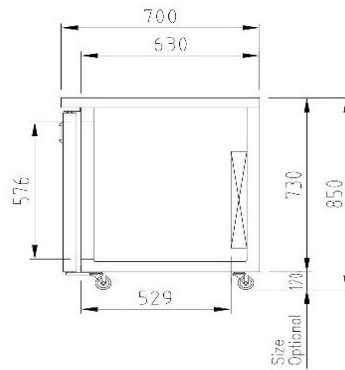

SIDE VIEW

Halo KSR18-3 Salad Prep Table 516 Ltrs RRP \$5450 + GST

3 Door Salad Prep Table Buffet Capacity 516 Ltrs

Dims : 1800 w x 700 d x 800 h (875mm high with castors) Weight 107kg

3 Door 3 shelves Refrigerant R134a Fan Cooling Type

Digital Control Amps 3 Voltage 220 / 50 Power 366 w

Door locks Interior LED lighting 4" swivel castors with front lock

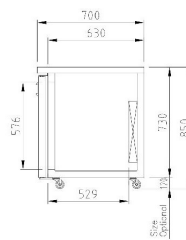

SIDE VIEW

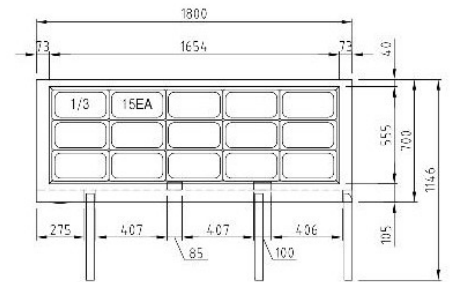

PLAN VIEW

Contact Halo Refrigeration

Phone : 1300 ORFORD (673 673)

Web : www.halorefrigeration.com.au

Sales@orford.com.au





halo®



HALO FOOD SERVICE K Series SALAD AND SANDWICH TABLES



Halo KHR9-1

Salad Table

RRP \$3350 + GST

Salad Side prep Table with hood
Capacity 213 Litres
Digital control

Dims : 900 w x 700 d x 978 h mm (1134 inc castors)
1 door 1 shelf
Amps 2.5, 314 w Power

Refrigerant : R134a

Weight 75 kg

Halo KHR12-2

Salad Table

RRP \$4350 + GST

Salad Side prep Table w hood
Capacity 309 Litres
Digital control

Dims : 1200 w x 700 d x 978 h mm (1134 inc castors)
2 door 2 shelves
Amps 3, 314 w Power

Refrigerant : R134a

Weight 89 kg



Halo KHR15-2

Salad Table

RRP \$4800 + GST

Salad Side prep Table with hood
Capacity 420 Litres
Digital control

Dims : 1500 w x 700 d x 978 h mm (1134 inc castors)
2 door 2 shelves
Amps 3, 314 w Power

Refrigerant : R134a

Weight 100 kg

Halo KHR18-3

Salad Table

RRP \$6200 + GST

Salad Side prep Table with hood

Dims : 1800 w x 700 d x 978 h mm (1134 inc castors) Capacity 516 Litres

3 door 3 shelves

Refrigerant : R134a

Digital control

Amps 4.4, 366 w Power

Weight 120 kg



Contact Halo Refrigeration

Phone : 1300 ORFORD (673 673)

Web : www.halorefrigeration.com.au

Sales@orford.com.au





halo®



HALO FOOD SERVICE OPEN CASES

PLAN VIEW

(unit : inch)

Halo OF300 Refrigerator RRP \$10,120 + GST

Open Face Refrigerator—mid height

Dimensions : 991 w x 771 d x 1660 h Capacity : 300 ltrs

Operating Temperature : 2—6 degrees

LED interior lighting Standard back guard to improve airflow

Energy saving night curtain standard

Front air intake and rear air discharge

3 shelves

Refrigerant : R-404a

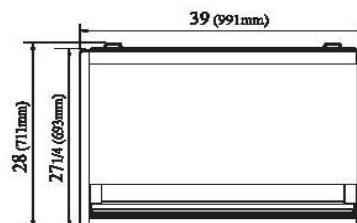

TOP VIEW

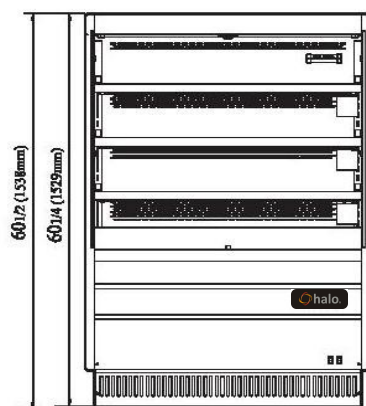

FRONT VIEW

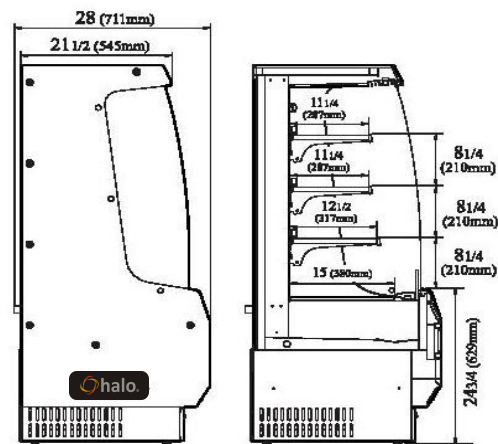

SIDE VIEW

(Interior)

Contact Halo Refrigeration

Phone : 1300 ORFORD (673 673)

Web : www.halorefrigeration.com.au

Sales@orford.com.au





halo®



HALO FOOD SERVICE OPEN CASES



Model	Capacity	Weight	Length	Depth	Height	Price ex GST
Halo OF 900	457lt	190kg	900	800	1500	\$9,353
Halo OF 1200	583lt	240kg	1200	800	1500	\$11,232
Halo OF 1500	709lt	270kg	1500	800	1500	\$12,759
Halo OF 1800	835lt	310kg	1800	800	1500	\$14,600

Halo OF Range Specifications

Operating Temperature : 5—10 degrees

Ambient temperature : 32 degrees

Refrigerant : R-404a

Digital Controller



Contact Halo Refrigeration

Phone : 1300 ORFORD (673 673)

Web : www.halorefrigeration.com.au

Sales@orford.com.au





halo®



HALO Cake Display / Bakery Cases



Model	Layers	Weight	Length	Depth	Height	Price ex GST
Halo CD900-2	2	190	900	800	1100	\$5914
Halo CD900-3	3	190	900	800	1300	\$7122
Halo CD1200-2	2	240	1200	800	1100	\$7014
Halo CD1200-3	3	240	1200	800	1300	\$8219
Halo CD1500-2	2	280	1500	800	1100	\$8095
Halo CD1500-3	3	280	1500	800	1300	\$9482
Halo CD1800-2	2	300	1800	800	1100	\$9421
Halo CD1800-3	3	300	1800	800	1300	\$11028
Halo CD2100-2	2	340	2100	800	1100	\$10815
Halo CD2100-3	3	340	2100	800	1300	\$12612
Halo CD2400-2	2	400	2400	800	1100	\$11750
Halo CD2400-3	3	400	2400	800	1300	\$13758

Contact Halo Refrigeration

Phone : 1300 ORFORD (673 673)

Web : www.halorefrigeration.com.au

Sales@orford.com.au





halo®



HALO Cake Display / Bakery Cases



Model	Layers	Weight	Length	Depth	Height	Price ex GST
Halo CD900-4	4	190	900	800	1500	\$8580
Halo CD900-5	5	190	900	800	1500	\$9420
Halo CD1200-4	4	240	1200	800	1500	\$9887
Halo CD1200-5	5	240	1200	800	1500	\$10695
Halo CD1500-4	4	280	1500	800	1500	\$11195
Halo CD1500-5	5	280	1500	800	1500	\$12187
Halo CD1800-4	4	300	1800	800	1500	\$12876
Halo CD1800-5	5	300	1800	800	1500	\$13956
Halo CD2100-4	4	340	2100	800	1500	\$14589
Halo CD2100-5	5	340	2100	800	1500	\$15698
Halo CD2400-4	4	400	2400	800	1500	\$15762
Halo CD2400-5	5	400	2400	800	1500	\$16998

Contact Halo Refrigeration

Phone : 1300 ORFORD (673 673)

Web : www.halorefrigeration.com.au

Sales@orford.com.au





halo®



HALO FOOD SERVICE OPEN DELI CASES

Halo MNY937 Open Deli Refrigerator RRP \$6800 + GST

Multi Deck Self contained refrigerator

ASPERA compressor

LED Lights

4 adjustable shelves plus Base night blind as standard

Refrigerant R404a

Temperature range 3—5 c at 25 degrees ambient

Low front 450 mm

Toughened Glass end walls for maximum display

Heavy duty castors

Digital temperature display

Dimensions : 937 w (1002 inc end walls) x 700 d (overhead canopy 800w) x 2000 h

Position cabinet a minimum of 100mm off walls to allow air flow

10 Amps



Halo MNY1250 Open Deli Refrigerator RRP \$8400 + GST

Multi Deck Self contained refrigerator

ASPERA compressor

LED Lights

4 adjustable shelves plus Base night blind as standard

Refrigerant R404a

Temperature range 3—5 c at 25 degrees ambient

Low front 450 mm

Toughened Glass end walls for maximum display

Heavy duty castors

Digital temperature display

Dimensions : 1250 w (1315 inc end walls) x 700 d (overhead canopy 800w) x 2000 h

Position cabinet a minimum of 100mm off walls to allow air flow

10 Amps



Contact Halo Refrigeration

Phone : 1300 ORFORD (673 673)

Web : www.halorefrigeration.com.au

Sales@orford.com.au





halo®



HALO FOOD SERVICE OPEN DELI CASES

Halo MNY 1875 Open Deli Refrigerator RRP \$10 450 + GST

Multi Deck Self contained refrigerator 1342 Litres
ASPERA compressor LED Lights
4 adjustable shelves plus Base night blind as standard
Refrigerant R404a
Temperature range 3—5 c at 25 degrees ambient
Low front 450 mm
Toughened Glass end walls for maximum display
Heavy duty castors Digital temperature display
Dimensions : 1875 w (1940 inc end walls) x 700 d (overhead canopy 800) x 2000 h
Position cabinet 100mm off walls to allow air flow
Power consumption (Kwh/24h) 35 15 Amps



Halo MNY2500 Open Deli Refrigerator RRP \$12450 + GST

Multi Deck Self contained refrigerator
ASPERA compressor LED Lights
4 adjustable shelves plus Base night blind as standard
Refrigerant R404a
Temperature range 3—5 c at 25 degrees ambient Low front 450 mm
Toughened Glass end walls for maximum display
Heavy duty castors Digital temperature display
Dimensions : 2500 w (2565 w inc end walls) x 700 d (overhead canopy 800) x 2000 h
Position cabinet 100 mm off walls to allow for air flow
Power consumption (Kwh/24h) 44 15 Amps Cabinet weight : 505kg



Contact Halo Refrigeration

Phone : 1300 ORFORD (673 673)

Web : www.halorefrigeration.com.au

Sales@orford.com.au





halo®



HALO FOOD SERVICE DELI CASES with DOOR

Halo MNYD 2500 Refrigerator RRP \$14,050 + GST

Multi Deck Self contained refrigerator with doors

ASPERA compressor

LED Lights

4 adjustable shelves plus Base night blind as standard

Refrigerant R404a

Temperature range 3—5 c at 25 degrees ambient

Low front 450 mm

Toughened Glass end walls for maximum display

Heavy duty castors

Digital temperature display

Dimensions : 2500 w (2565 w inc end walls) x 725d (overhead canopy 800) x 2000 h

Position cabinet 100 mm off walls to allow for air flow

Power consumption (15.6kwh/24h)

15 Amps

Cabinet weight : 505kg



Contact Halo Refrigeration

Phone : 1300 ORFORD (673 673)

Web : www.halorefrigeration.com.au

Sales@orford.com.au





HALO FOOD SERVICE RANGE



Value add to your fridge

Add an opaque front to your glass door fridge for a Euro look

\$120 + GST per fridge door



Contact Halo Refrigeration

Phone : 1300 ORFORD (673 673)

Web : www.halorefrigeration.com.au

Sales@orford.com.au





CyberChill

REFRIGERATION



- **Wall Cabinets**

Stainless steel interior & exterior

- High ambient (43°C) refrigeration system
- Zero ODP injected polyurethane insulation
- i'Cool energy saving controller with alarms
- Gastronorm GN 1/1 shelving system
- Easy to clean covered interior and base
- Self closing doors
- Removable magnetic door gasket
- Heavy duty brake and swivel castors
- Removable racking system with anti-tilt slides
- Waste heat vaporiser
- Wall mounting kit
- Left hand condensing units



Contact Halo Refrigeration

Phone : 1300 ORFORD (673 673)

Web : www.halorefrigeration.com.au

Sales@orford.com.au





CyberChill REFRIGERATION

CyberChill Cold & Freezer Rooms

- 40°C ambient refrigeration system
- Modular insulated panels - any size room
- 75 / 100mm, high density polyurethane panels & floor
- Zero ODP injected polyurethane insulation
- White colorbond finish - interior / exterior
- Durable chequer-plate flooring
- Unique tongue & groove, cam-lock construction
- Soft rubber gasket between all joints - no need for silicon
- Simple, quick assembly / disassembly
- Wide 180°, recessed hinged door opening - 900mm x 1900mm (h)
- Internal, luminous, door safety release
- Kason latch (lockable) & strike, Kason self-raising hinges
- Hydraulic door closer, ensuring air-tight seal
- Heated door-frame & pressure relief valve
- Light switch with indicator on/off lamp



Contact Halo Refrigeration

Phone : 1300 ORFORD (673 673)

Web : www.halorefrigeration.com.au

Sales@orford.com.au





Medical Fridges by Halo

Halo Medisafe MF 80G2

80 Litre

RRP \$2450 + GST

Dimensions : 500w x 560d x 830h (mm)

Free standing single door cabinet

Power Consumption : 3.08Kwh / 24 Hrs

Fully Approved - SAA Electrical - EMC (C-Tick) - QCPP Approved (Quality Care Pharmacy Program)

White with Silver Doors

4 adjustable feet 2 shelves

Weight : 66kg

Purpose built QCPP accredited vaccine refrigerator with complete electronic monitoring system maintaining same temperature on each shelf.

Easy to use data logger to download temperature history with ease.

- Data logger includes visual alert, records minimum and maximum temperatures and power failure alarm. Battery back up allows for temperature recordings even during a power outage. Temperature readings can be downloaded to a computer.
- ABS and double glazed door.
- +2°C to +8°C in ambient 32°C. with a CAREL controller
- 240V 50Hz , 250Watt.
- Forced air ventilation, excellent chilling.
- Internal light.
- Sound Level DBA 55.
- Lock fitted.
- Complete 100% reliability guaranteed.
- Australian Commercial **MEPS** Approved.
- Also International ISO9001, 14001 + OHSAS 18001 Certified.

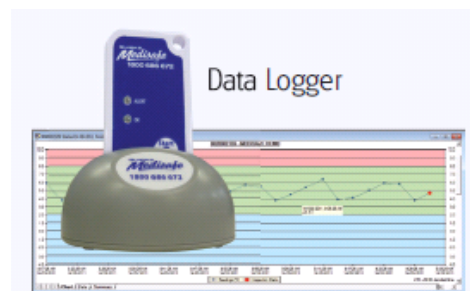
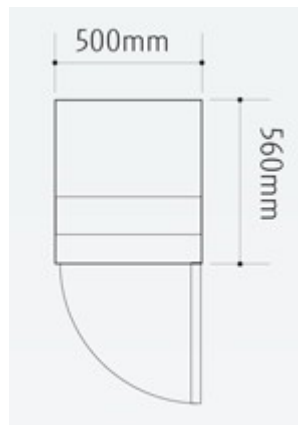

Contact Halo Refrigeration

Phone : 1300 673 673

Web : www.halorefrigeration.com.au

Sales@halorefrigeration.com.au





Medical Fridges by Halo

Halo Medisafe MF 371G2

381 Litre

RRP\$3950 + GST

Dimensions : 595w x 595d x 1930h (mm)

Capacity : 381 Litres

Door opened width : 1180mm

Power Consumption : 4.17 Kwh / 24 Hrs

Fully Approved - MEPS - SAA Electrical - EMC (C-Tick) - QCPP Approved (Quality Care Pharmacy Program)

White with Silver Doors

4 adjustable feet

5 x full sized shelves plus 1 x 1/2 sized industrial shelf

Weight : 93kg



Purpose built QCPP accredited vaccine refrigerator with complete electronic monitoring system maintaining same temperature on each shelf.

- W: 595mm x D: 595mm x H: 1930mm.
- 10mm feet.
- Allow 10mm for door swing, unit is 1180mm with open door.
- Depth is 640mm including handle.
- Easy to use data logger to download temperature history with ease.
- Data Logger includes visual alert, records minimum and maximum temperatures and power failure alarm.
- ABS and double glazed door.
- 2°C>8°C in ambient 32°C.
- 240V 50Hz , 250Watt.
- Silver door frame and white body.
- Forced air ventilation, excellent chilling.
- Internal light.
- Reversible door available on request, lock fitted.
- Noise Level: DBA 55.
- Lock fitted.
- Fits 476 x cans.
- Complete 100% reliability guaranteed
- Also International ISO9001, 14001 + OHSAS 18001 Certified

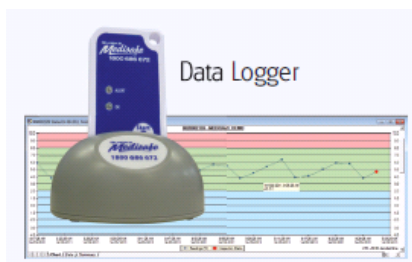
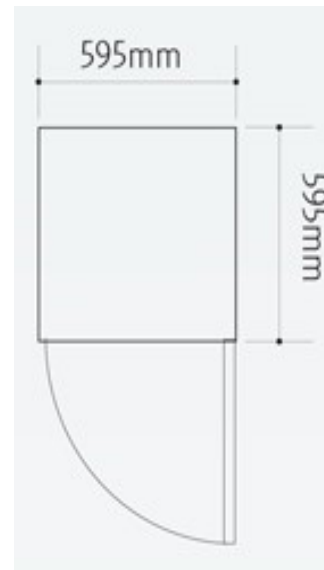

Contact Halo Refrigeration

Phone : 1300 673 673

Web : www.halorefrigeration.com.au

Sales@halorefrigeration.com.au





Medical Fridges by Halo



Halo Medisafe MF 311G2

306 Litre

\$3750 + GST

Dimensions : 595w x 595d x 1630h (mm)

Capacity : 306 Litres

Door opened width : 1180mm

Power Consumption : 3.69 Kwh / 24 Hrs

Fully Approved - MEPS - SAA Electrical - EMC (C-Tick) - QCPP Approved (Quality Care Pharmacy Program)

White with Silver Doors

4 adjustable feet

4 x full sized shelves plus 1 x 1/2 sized industrial shelf

Weight : 74kg

Purpose built QCPP accredited vaccine refrigerator with complete electronic monitoring system maintaining same temperature on each shelf.

Depth is 640mm including handle.

- Easy to use data logger to download temperature history with ease.
- Data logger includes visual alert, records minimum and maximum temperatures and power failure alarm.
- ABS and double glazed door.
- 2°C>8°C in ambient 32°C.
- Silver door frame and white body.
- Forced air ventilation, excellent chilling.
- Internal light.
- Energy efficient, 3.69Kwh / 24Hr.
- Stylish look.
- Reversible door available on request, lock included.
- Noise level DBA 55.
- Complete 100% reliability guaranteed.
- Australian Commercial **MEPS** Approved.
- Also International ISO9001, 14001 + OHSAS 18001 Certified

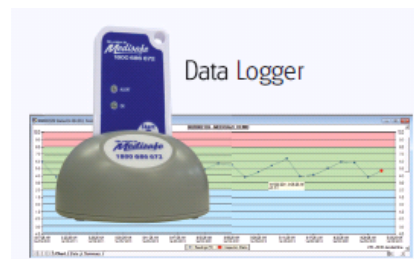
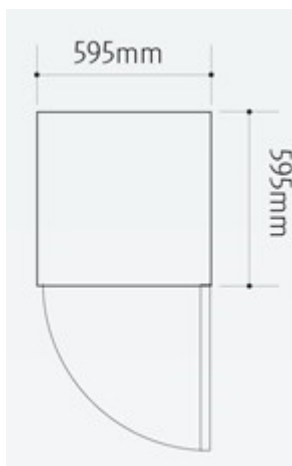

Contact Halo Refrigeration

Phone : 1300 673 673

Web : www.halorefrigeration.com.au

Sales@halorefrigeration.com.au





Halo 20 cb —Hotel Beverage Dispenser

\$980+ GST

Halo 20 —*Hotel Beverage dispenser*

The Halo 20 is a chilled Beverage dispenser Ideal for storing, chilling and dispensing milk and is built to withstand the demands of high traffic areas such as Hotels, Resorts, Clubs, Pubs, Cafeterias, etc.

Operates at +2 degrees to + 6 degrees at 35 degrees ambient temp and 60% humidity

Energy consumption .85 KwH/24hrs



Halo 20 Specifications	Refrigerated Milk Dispenser
Construction	White colorbond
Capacity	2 x 20 Litre Milk Bladders
Dimensions	380 W x 452 D x 810 H
Ext Dimensions	330W x 270 D x 420 H
Weight	35Kg
Operating Temp	+2° - +6° C.
Ambient Temperature	0—30° C.
Power Point	220 - 240v 50Hz. (Standard GPO)
Thermometer	Mechanical Controller
Doors	1 x Colorbond with outer illuminated LED sign box
Footing	Flat Base

Contact Halo Refrigeration

Phone : 1300 ORFORD (673 673)

Web : www.halorefrigeration.com.au

Sales@orford.com.au





halo®



Manitowoc Ice Machines



Manitowoc Sotto UG30

Production 31kg / 24 hrs @ 21c Air
Production 25kg / 24 hrs @ 32c Air
Ice Storage 10kg
450w x 475d x 650h (ex legs) Ice type - Octagon
Bin integral Optional set of 4 legs for \$70 + GST

Manitowoc Sotto UG50

Production 57kg / 24 hrs @ 21 c Air
Production 43kg / 24 hrs @ 32 c Air
Ice storage 25kg
550w x 550d x 800h (ex legs) Ice type - Octagon
Bin Integral Optional set of 4 legs for \$70 + GST



Manitowoc Sotto UG65

Production 65kg / 24hrs @ 21c Air
Production 58kg / 24hrs @ 32c Air
Ice Storage 44kg
700w x 600d x 900h (mm) excludes legs
Ice type - Octagon Bin Integral Optional set of 4 legs for \$70 + GST

Manitowoc Sotto UG80

Production 85kg / 24hrs @ 21c Air
Production 67kg / 24hrs @ 32c Air
Ice storage 44kg
700 w x 600d x 900h (mm) excludes legs
Ice type - Octagon Bin integral Optional set of 4 legs for \$70 + GST



Contact Halo Refrigeration

Phone : 1300 673 673

Web : www.halorefrigeration.com.au

Sales@halorefrigeration.com.au





View our other catalogues

www.orford.com.au



Contact Halo Refrigeration

Phone : 1300 673 673

Web : www.halorefrigeration.com.au

Sales@halorefrigeration.com.au





halo®



www.halorefrigeration.com.au

Refrigeration Solutions

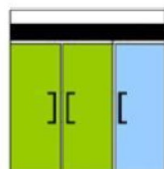

Contact Halo Refrigeration

Phone : 1300 673 673

Web : www.halorefrigeration.com.au

Sales@halorefrigeration.com.au





Head Office

Unit 5, Quantum Business Park

1 Gardner Crt

Wilsonton Qld 4350

Postal Address

PO Box 18120

Clifford Gardens

Qld 4350

ABN : 72 150865008

National Number :

1300 ORFORD (1300 673 673)

National Spare Parts :

0448 ORFORD (0448 673 673)

National Sales :

Jeff Ash : 0400 013 958

Email : Jeffash@orford.com.au

www.orford.com.au

Sales Enquiries :

Email : sales@orford.com.au

Corby Orford : 0418 700006

Email : corby@orford.com.au

Phone : 1300 ORFORD (1300 673 673)

Our websites :

www.orford.com.au

www.flowerfridges4u.com.au

www.halorefrigeration.com.au

www.orforddigital.com.au

www.chocolatefridges4u.com.au

www.icemachines4u.com.au

Orford Refrigeration and Halo Refrigeration reserve the

Right to adjust pricing and specification as required.

